



INSTALLATION and SERVICE INSTRUCTIONS
USE and CARE INSTRUCTIONS

OVENS



Living innovation

distributed by
DeLonghi

Pty Ltd

Dear Customer,

Thank you for having purchased and given your preference to our product.

The safety precautions and recommendations reported below are for your own safety and that of others. They will also provide a means by which to make full use of the features offered by your appliance.

Please keep this booklet in a safe place. It may be useful in future, either to yourself or to others in the event that doubts should arise relating to its operation.

This appliance must be used only for the task it has explicitly been designed for, that is for cooking foodstuffs. Any other form of usage is to be considered as inappropriate and therefore dangerous.

The manufacturer declines all responsibility in the event of damage caused by improper, incorrect or illogical use of the appliance or by faulty installation.

PRODUCT LABEL



CONTENTS

Precautions and recommendations	4
Installation.....	5
Multifunction oven - Use and care	12
Plurifunction oven - Use and care	24
Cleaning and maintenance.....	32

USING THE OVEN FOR THE FIRST TIME

You are advised to carry out the following operations:

- Furnish the interior of the oven.
- Switch the empty oven ON at maximum temperature for about two hours to eliminate traces of grease and smell from the components.
- Clean the interior of the oven with a cloth soaked in water and neutral detergent and dry thoroughly.

IMPORTANT PRECAUTIONS AND RECOMMENDATIONS FOR USE OF ELECTRICAL APPLIANCES

Use of any electrical appliance implies the necessity to follow a series of fundamental rules. In particular:

- Never touch the appliance with wet hands or feet;
- Do not operate the appliance barefooted;
- The appliance is not intended for use by young children or infirm persons with supervision
- Young children should be supervised to ensure they do not play with the appliance

The manufacturer cannot be held responsible for any damages caused by improper, incorrect or illogical use of the appliance.

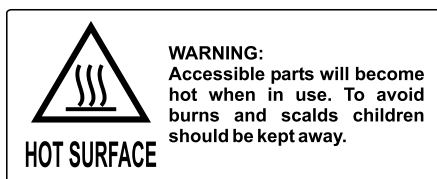

IMPORTANT PRECAUTIONS AND RECOMMENDATIONS

After having unpacked the appliance, check to ensure that it is not damaged. In case of doubt, do not use it and consult your supplier or a professionally qualified technician.

Packing elements (i.e. plastic bags, polystyrene foam, nails, packing straps, etc.) should not be left around within easy reach of children, as these may cause serious injuries.

- Do not attempt to modify the technical characteristics of the appliance as this may become dangerous to use.
- Do not carry out cleaning or maintenance operations on the appliance without having previously disconnected it from the electric power supply.
- After use, ensure that the knobs are in the off position.
- Do not allow children or other incapable people to use the appliance without supervision.
- During use the appliance becomes hot. Care should be taken to avoid touching heating elements inside the oven.
- Keep children away from the cooker when it is in use.
- Some appliances are supplied with a protective film on steel and aluminium parts. This film must be removed before using the appliance.
- Fire risk! Do not store flammable material in the oven.
- Make sure that electrical cables connecting other appliances in the proximity of the oven become entrapped in the oven door.
- Do not line the oven walls with aluminium foil. Do not place baking trays or the drip tray on the base of the oven chamber.
- The manufacturer declines all liability for injury to persons or damage to property caused by incorrect or improper use of the appliance.

- **WARNING: Taking care NOT to lift the oven by the door handle.**
- **IMPORTANT NOTE: This appliance shall not be used as a space heater, especially if installed in marine craft or caravans.**

This oven has been designed and constructed in accordance with the following codes and specifications:

AS/NZS 3350-1	General Requirements for Domestic electrical appliances
AS/NSZ 3350-2-6	Particular Requirements for Domestic electrical cooking appliances
AS/NSZ 1044	Electromagnetic Compatibility Requirements.

INSTALLATION

CAUTION:

- **This appliance must be installed in accordance with these installation instructions.**
- **This appliance shall only be serviced by authorized personnel.**
- **This appliance is to be installed only by an authorised person.**
- **Incorrect installation, for which the manufacturer accepts no responsibility, may cause personal injury or damage.**
- **Always disconnect the oven from mains power supply before carrying out any maintenance operations or repairs.**

ELECTRICAL REQUIREMENTS

- The oven is supplied without a power supply plug and therefore if you are not connecting directly to the mains, a standardized plug suitable for the load must be fitted.
- Connection to the mains must be carried out by qualified personnel in accordance with current regulations.
- The appliance must be connected to the mains checking that the voltage corresponds to the value given in the rating plate and that the electrical cable sections can withstand the load specified on the plate.
- The plug must be connected to an earthed socket in compliance with safety standards.
- The appliance must be connected directly to the mains placing a two pole switch with minimum opening between the contacts of 3 mm between the appliance and the mains.
- The power supply cable must not touch the hot parts and must be positioned so that it does not exceed 75°C at any point.
- Once the appliance has been installed, the switch or socket must always be accessible.
- **If the supply cord is damaged it must be replaced by the manufacturer or its Service Agent or a similarly qualified person in order to avoid a hazard.**

- N.B. ■ The connection of the appliance to earth is mandatory.**
■ **For connection to the mains, do not use adapters, reducers or branching devices as they can cause overheating and burning.**

If the installation requires alterations to the domestic electrical system call a qualified electrician. He should also check that the socket cable section is suitable for the power drawn by the appliance.

REPAIRS

REPLACING THE POWER SUPPLY CABLE

- Unhook the terminal board cover by inserting a screwdriver into the two hooks "A" (fig. 2).
- Open the cable gland by unscrewing screw "F" (fig. 3), unscrew the terminal screws and remove the cable.
- The new supply cable, of suitable type and section, is connected to the terminal board following the diagram fig. 1.

FEEDER CABLE SECTION TYPE HO5RR-F

230 V ~ 3 x 1,5 mm²

Figure 1

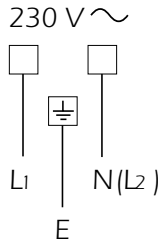

Figure 2

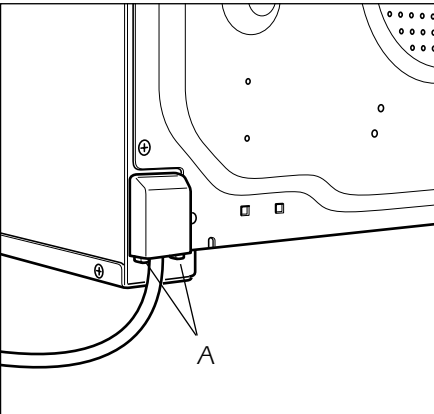
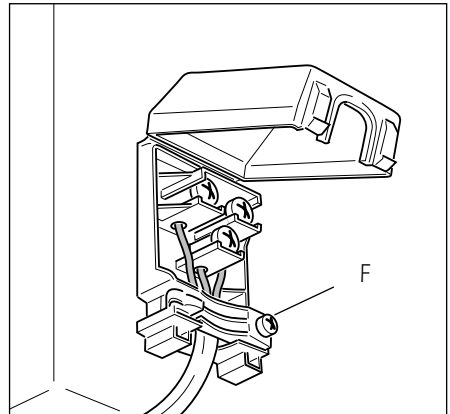
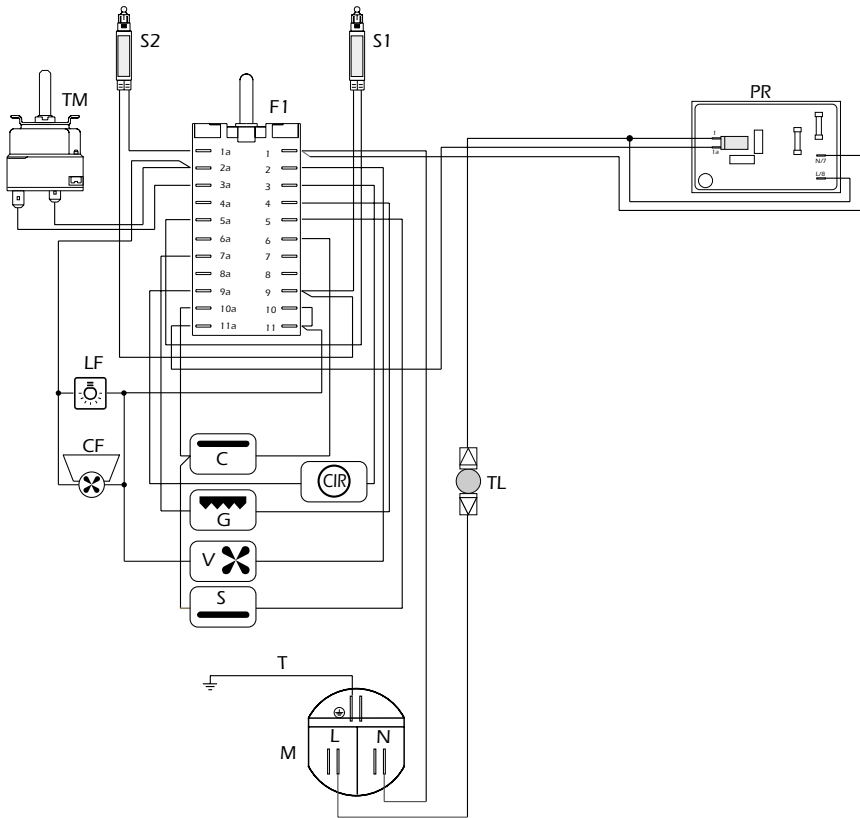

Figure 3



ELECTRIC DIAGRAM - multifunction OVENS

Figure 4



- F1 Oven switch
- TM Oven thermostat
- TL Thermal overload
- PR Electronic programmer
- LF Oven lamp
- S1 Thermostat pilot lamp
- S2 Line pilot lamp
- C Top element
- G Grill element
- S Bottom element
- V Fan
- CIR Circular element
- CF Cooling fan
- M Terminal block
- T Earth connection

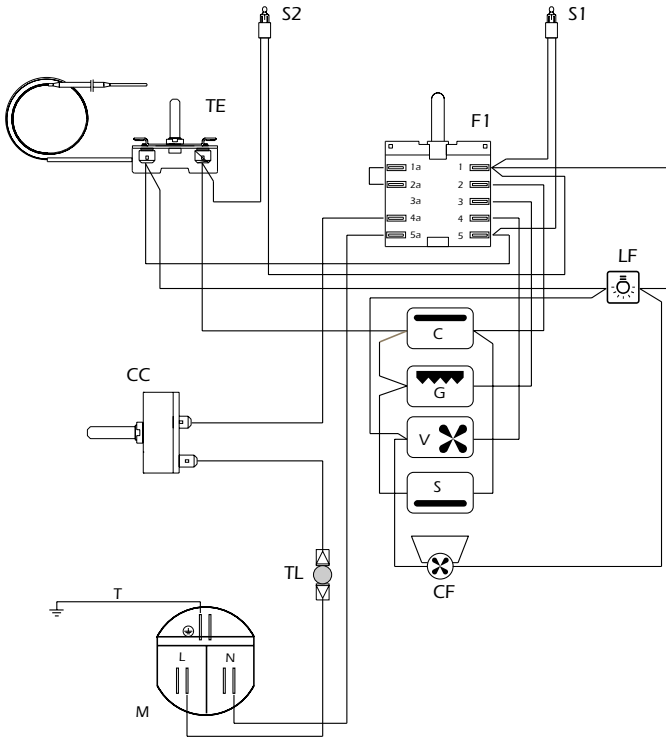

- F1 Oven switch
- TE Oven thermostat
- LF Oven lamp
- CC Oven cut-off
- S1 Line pilot lamp
- S2 Thermostat pilot lamp
- TL Thermal overload
- M Terminal block
- C Top element
- G Grill element
- S Bottom element
- CF Cooling fan
- V Fan
- T Earth connection

FITTING REQUIREMENTS

WARNING: Taking care NOT to lift the oven by the door handle.

The oven must be built-in in a standard module of furniture of 60 cm width and depth.

It is to be fit up in a module having the clearance as shown in the pictures.

On the lower side, the oven must lay on supports standing the oven weight.

The ovens are secured by four screws that pass through the surround. They must locate firmly and squarely in the edges of the cabinet or add panels to achieve a secure location.

Figure 6

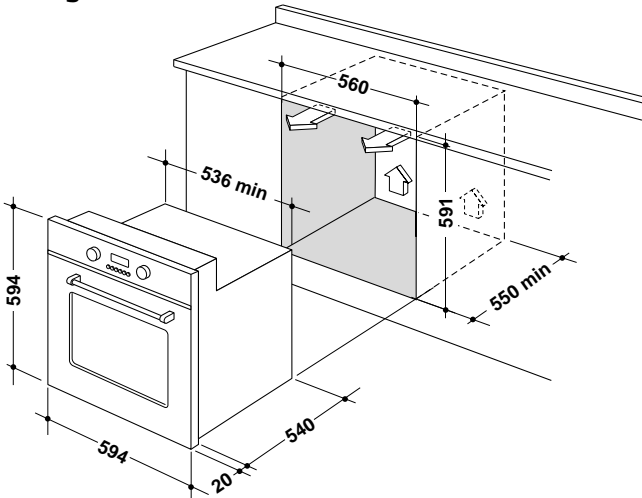

The walls surrounding the oven must be made of heat-resistant material. Both the veneered plastic and the adhesive used must be resistant to temperatures of 120°C in order to prevent unsticking and deformation.

FITTING THE OVEN INTO A BASE

The space available should be of the dimensions shown in the figure 6.

Arrangements should be made for an adequate supply of the air to the oven to avoid overheating (fig. 7).

Figure 7

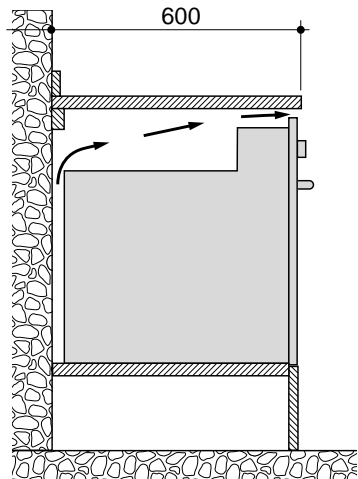

Figure 8

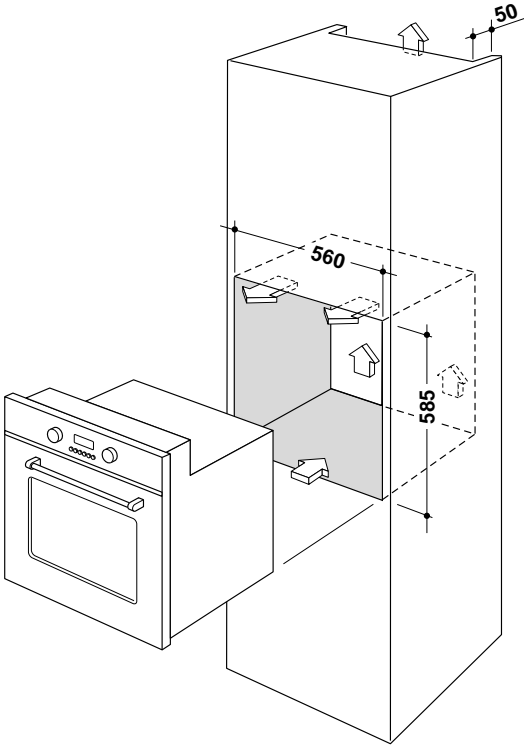
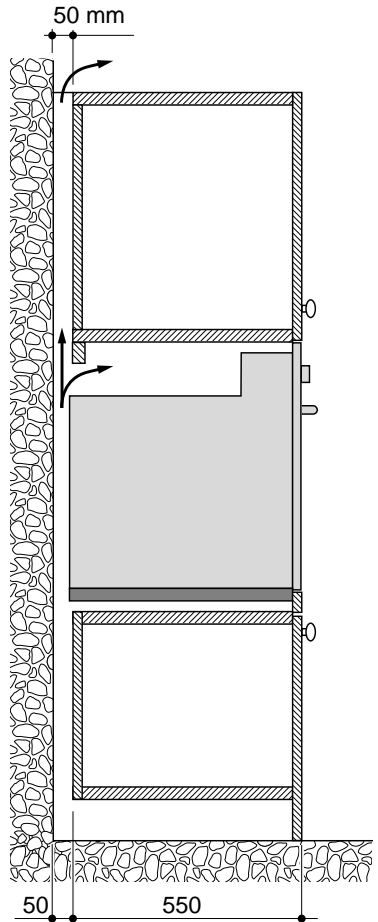

Figure 9



FITTING THE OVEN INTO A COLUMN

The cabinet should have the dimensions as per fig. 8. Furthermore it is necessary that the oven is provided with a chimney as per fig. 9. If the column unit reaches the ceiling an outlet must be provided through which air can flow to the outside

Figure 10

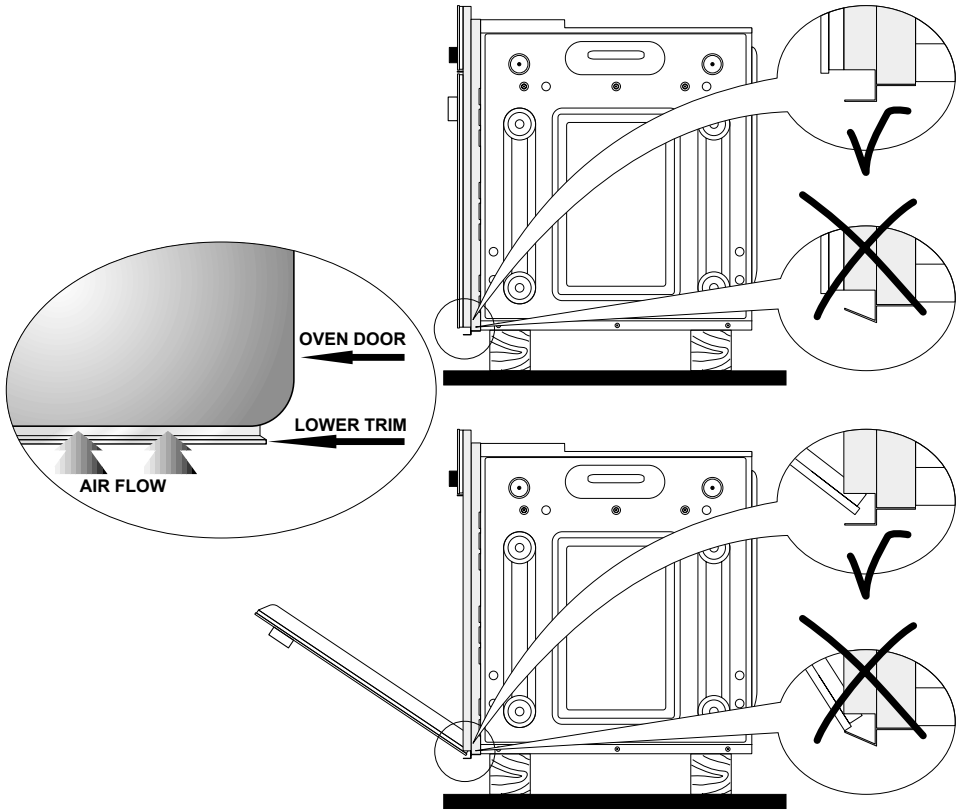

IMPORTANT:

Please take extra care not to damage the lower trim of the oven.

Ensure the oven sits on wooden blocks or similar supports when it is removed from the carton as shown in above diagram. This will prevent any damage to the lower trim.

Should the lower trim become damaged, straighten the trim and ensure the oven door opens fully without obstruction from the lower trim.

After installation check the lower trim is still undamaged.

The space between the bottom of the door & the lower trim is important to allow proper air circulation into the oven.

The oven door should be opened slowly to its fully open position ensuring there is adequate clearance between the bottom of the door and the lower trim.

The manufacturer does not accept responsibility for any damage to the oven resulting from incorrect installation.

USE and CARE

MULTIFUNCTION OVEN

CAUTION:

- This appliance must be used only for the task it has explicitly been designed for, that is for domestic cooking of foodstuffs. Any other form of usage is to be considered as inappropriate and therefore dangerous.
- Do NOT place combustible materials or products on this appliance at any time.

SLIDING SHELVES

- They facilitate the insertion and removal of shelves during cooking. These shelves support all accessory trays and are dishwasher safe.
- The shelves stop when pulled out to the maximum position.
- The sliding shelves can be removed easily by unscrewing the fixing screws and detaching them from the oven walls.
- Removing the sliding shelves improves access to the oven ceiling for cleaning (after the grill heating element has been lowered).

Figure 10

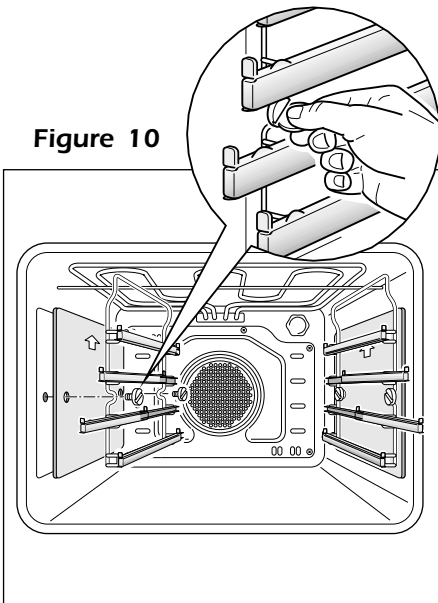
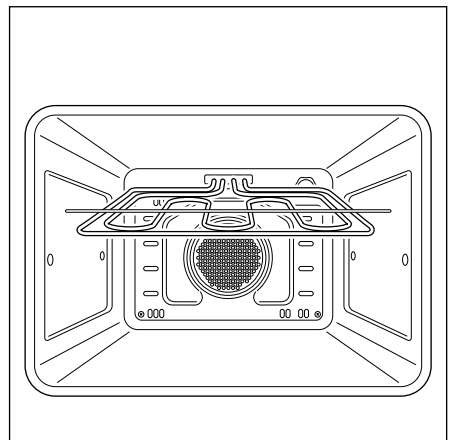





Figure 12



USING THE OVEN FOR THE FIRST TIME

- Slide in the catalytic liners and sliding shelves on the oven wall as in Fig. 11.
- Slide in the grease filter on the back of the oven as in Fig. 14.
- Position the shelf and tray on the sliding shelves (fig. 13).
- To eliminate traces of grease and smell from the components it is necessary to pre-heat the oven at the maximum temperature.
 - For 60 minutes in the  position, for 30 minutes in the  position and for another 15 minutes in the  position.
- Slide off the sliding shelves and the catalytic liners to the oven wall as in Fig. 11. The grill is secured to the rear wall of the oven on a hinge system that allows it to be lowered to allow proper access when cleaning the oven ceiling (fig. 12).
- Clean the inside of the oven with a cloth soaked in water and neutral detergent and dry thoroughly.

GREASE FILTER

- A special screen is provided at the back of the oven to catch grease particles, mainly when meat is being roasted (fig. 14).
- When baking pastry etc. this filter should be removed.
- Always clean the filter after cooking as any solid residues on it might adversely affect the oven performance.

Figure 13

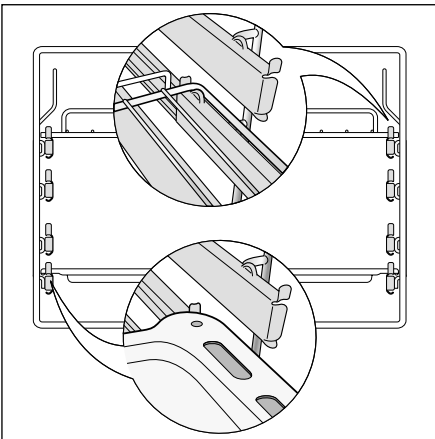
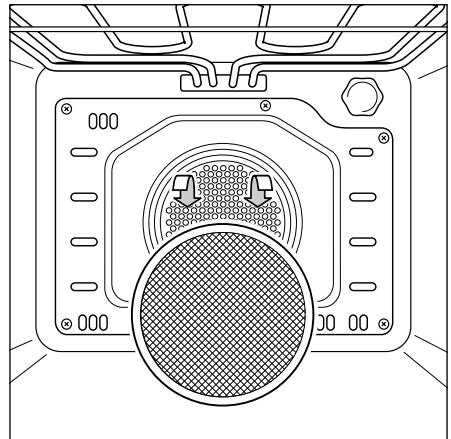
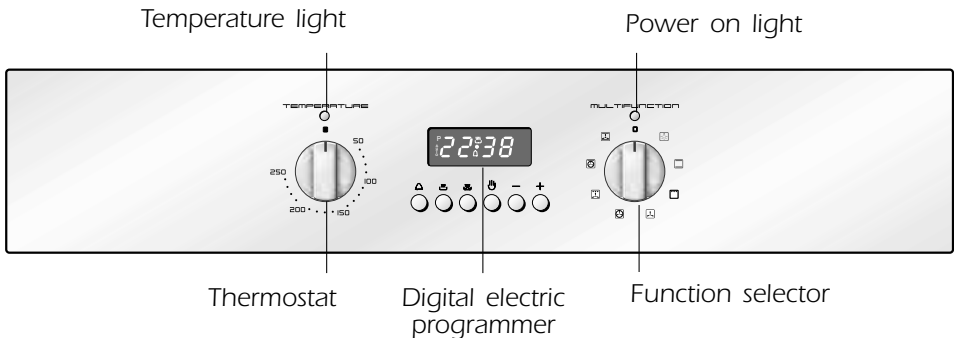

Figure 14



Cooking with multifunction oven

Figure 15



GENERAL FEATURES

With your new Multi-Function oven it is possible to cook a variety of food using the 7 different cooking functions.

These 7 functions are obtained using a combination of the 4 different heating elements plus a defrost function using the fan only.



OPERATING PRINCIPLES

Heating and cooking in the MULTI-FUNCTION oven are obtained in the following ways:

a. by normal convection

The heat is produced by the upper and lower heating elements.

b. by forced convection

The fan draws in air contained within the oven housing at the rear of the oven and forces it over the circular heating element. The hot air envelops the food in the oven giving faster and more even cooking before it is drawn back into the housing to repeat the cycle. It is possible to cook several dishes simultaneously due to the even distribution of heat within the oven.

c. by forced semi-convection

The heat produced by the top and bottom heating elements is distributed throughout the oven by the fan.

d. by radiant heat

The food is grilled by the infra red grill element.

e. by radiant heat and ventilation

The food is grilled by the grill element is distributed throughout the oven

f. by ventilation

The food is defrosted by using the fan only function without heat.

Figure 16

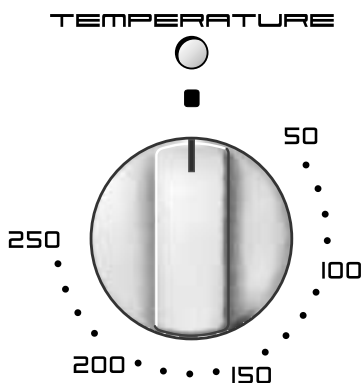

TEMPERATURE KNOB

This only sets the cooking temperature and does not switch the oven on. Rotate clockwise until the required temperature is reached (from 50 to 250°C).

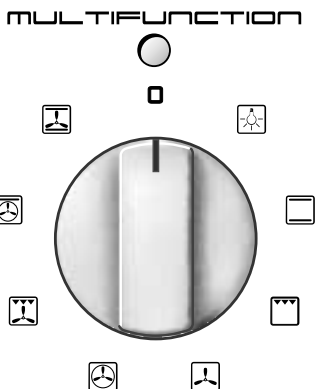

MULTIFUNCTION KNOB

Rotate the knob clockwise to set the oven for one of the following functions.



OVEN LIGHT

By setting the knob to this position, only the oven light comes on. It remains on in all the cooking modes.



TRADITIONAL CONVECTION COOKING

The upper and lower heating elements come on. The heat being dispersed by natural convection. The temperature range must be set between 50°C and 250°C using the thermostat.

The oven must be preheated before cooking.

Ideal for:

Food that requires the same degree of cooking both inside and out, for example roasts, spare pork ribs, meringues etc.



GRILLING

The infrared grill element at the top of the oven comes on. The heat is dispersed by radiation.

Use with the **oven door closed** and the thermostat knob to position between 50°C and 200°C max.

For cooking hints, see the chapter "USE OF THE GRILL".

Recommended for:

Intense grilling, browning, cooking au gratin and toasting etc.



DEFROST

Only the oven fan comes on. Use with the thermostat knob set to "■" - other temperature have no effect. The food is thawed by ventilation without heating.

Ideal for:

Quick thawing of frozen foods; one kg requires approximately 1 hour.

Thawing times vary according to the quantity and type of food to be thawed.



FAN FORCED

The circular element and fan come on. The heat is dispersed by forced convection and the temperature can be varied to between 50° and 250°C via the thermostat knob. The oven does not require preheating.

Recommended for:

Food which has to be well-cooked outside and soft or rosy inside, for example lasagne, lamb, roast beef, whole fish etc.



FAN GRILL

Both the grill and the fan come on. Most of the cooking is done by grilling and then the hot air circulated around the oven. The oven door should be kept **closed**.

The temperature can be set between 50°C and 200°C max.

The oven should be preheated for 5 minutes before cooking. For further cooking hints see "GRILLING AND COOKING AU GRATIN".

Ideal for:

Quick sealing in of food juices for example such as hamburger, chicken pieces, chops.



MAINTAINING TEMPERATURE AFTER COOKING OR SLOWLY HEATING FOODS

The upper element, the circular element and the fan come on. The heat is circulated by forced convection with greater intensity in the upper part. The temperature can be set to between 50° and 140°C via the thermostat knob.

Recommended for:

Keeping food warm after any type of cooking. Slow heating of cooked food.



MULTI-FUNCTION

The upper and lower heating elements come on and the fan come on - the heat from the element being circulated by the fan. The temperature range can be set to between 50° and 250°C using the thermostat.

Ideal for:

Large bulky quantities of food that require even cooking throughout for example large roasts, turkey, roast turkey, cakes etc.

COOKING ADVICE

Remember to keep children away from the appliance when you use the grill or oven, since these parts become very hot.

STERILIZATION

Sterilization of foods to be preserved, in full and hermetically sealed jars, is done in the following way:

- Set the switch to position .
- Set the thermostat knob to position 185 °C and preheat the oven.
- Fill the dripping pan with hot water.
- Set the jars onto the dripping pan making sure they do not touch each other and the door and set the thermostat knob to position 135 °C.

When sterilization has begun, that is, when the contents of the jars start to bubble, turn off the oven and let cool.

Check your recipe book for full instructions.

WARMING BREAD

Set the switch to position  and the thermostat knob to position 150° C. Bread becomes fragrant again if wet with a few drops of water and put into the oven for about 10 minutes at the highest temperature.

SIMULTANEOUS COOKING OF DIFFERENT FOODS

The oven set on position  can cook several different foods together. Foods as diverse as fish and cakes can be cooked together without the cross transference of flavours. This is because the fats and cooking smell that would normally be deposited on the different foods are oxidised and are not absorbed by the foods. The cooking temperature of the foods, however must be within 20°-25°C of each other. The food with the longest cooking time will be put into the oven first and the other foods are added as necessary according to their cooking times.

ROASTING

To obtain classical roasting, it is necessary to remember:

- that it is advisable to maintain a temperature between 180° and 200 °C.
- that the cooking time depends on the quantity and the type of foods.

GRILLING AND “AU GRATIN”

As the hot air completely covers the food to be cooked, grilling may be done with the food on the rack in the oven. The knob should be switched to position . The thermostat should be set to 50°C and 200°C max and the oven pre-heated. The food should be placed on a rack in the oven for the required cooking time. Adding a few dabs of butter before the end of the cooking time gives the golden “au gratin” effect.

USE OF THE GRILL

Preheat the oven for about 5 minutes with the door closed.

Introduce the food to be cooked, positioning the rack as close to the grill as possible.

The dripping pan should be placed under the rack to catch the cooking juices and fats.







WARNING: Accessible parts may become hot when the grill is used. Children should be kept away.

Electronic programmer

The electronic programmer is a device which groups together the following functions:

- 24 hours clock with illuminated display
- Timer (up to 23 hours and 59 minutes)
- Program for automatic oven cooking
- Program for semi-automatic oven cooking

Description of the buttons:

-  Timer
-  Cooking time
-  End of cooking time
-  Manual position; and cancels the set program
-  Plus function to increase the number shown on the display
-  Minus function to decrease the number shown on the display or to change the buzzer frequency

Description of the illuminated symbols:

AUTO -flashing - Programmer in automatic position but not programmed

AUTO - always illuminated - Programmer in automatic position with program inserted.

 Automatic cooking taking place

 Timer in operation

 and **AUTO** - flashing - Program error.
(The time of day lies between the calculated cooking start and end time).

Note:

Select a function by the respective button and, in 5 seconds, set the required time with the $+$ / $-$ buttons ("one-hand" operation).

A power cut will reset the clock to zero and cancels the set programs.

Figure 17



ELECTRONIC CLOCK (fig. 18)



The illuminated figures on the clock represent hours and minutes on 24 hour clock. When first connected, or after a power failure, three zeros will flash on the display. To set the time press the  button and then the + or -
Please note that changing the hour button deletes any cooking program.

Figure 18



NORMAL COOKING WITHOUT THE USE OF THE PROGRAMMER

To manually use the oven without the aid of the programmer, it is necessary to cancel the flashing AUTO by pushing the button  (AUTO will be switched off and the symbol  will come on - Fig. 19).







Attention: If the **AUTO** symbol is on, a cooking program has already been programmed. By pressing the  you can cancel the set program & switch to manual mode. If the oven is switched on, you must manually switch it off.

Figure 19



ELECTRONIC TIMER

The timer program consists only of a buzzer which may be set for a maximum period of 23 hours and 59 minutes. If **AUTO** is flashing on the panel, push the  button. To set the time, push the  button and the  or  until you obtain the desired time on the panel (fig. 20).

Having finished the setting, the clock hour will appear on the panel and the  will be illuminated.

The countdown will start immediately and the time remaining is shown by pressing the .

At the end of the elapsed time, the  will go out and an intermittent buzzer will go off; this can be stopped by pressing any of the buttons.

SETTING THE FREQUENCY OF THE AUDIBLE SIGNAL

The selection from 3 possibilities of sound can be made by pressing the  button.

Figure 20







AUTOMATIC OVEN COOKING



To cook food automatically in the oven, it is necessary to:

1. Set the length of the cooking time
2. Set the end of the cooking time
3. Set the temperature and the oven cooking program.

These operations are performed as follows:

1. Set the length of the cooking time by pushing the  button and the $+$ button to advance, or $-$ to go back if you have passed the desired time (fig. 21). The **AUTO** and the  symbol will be on.
2. Set the end of the cooking time by pressing the  button (the cooking time already added to the clock time will appear), and the $+$ button (fig. 22); if you pass the desired time you may get back by pushing the $-$ button. After this setting, the  symbol will go off. If after this setting, the **AUTO** flashes on the panel and a buzzer sounds, it means there was an error in the programming. If this is the case, modify the end of cooking time or the cooking time itself by repeating the procedure above.
3. Set the temperature and the cooking program by using the switch and thermostat knobs of the oven (see specific chapters).

The oven is now set to turn on and off at the programmed times.

During cooking, the  symbol remains on. By pushing the  button you can see the time that remains until the end of cooking.

The cooking program may be cancelled in any time by pushing .

At the end of the cooking time the oven will turn off automatically, the  symbol will turn off, **AUTO** will flash and a buzzer will sound, which can be turned off by pushing any of the buttons.

Turn the temperature and thermostat knobs to zero and set the programmer to "manual" by pressing the .

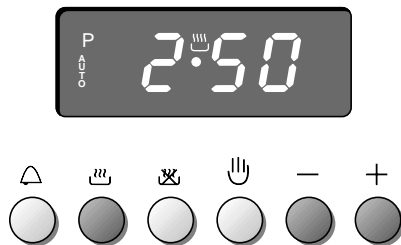

Attention: A power failure resets the clock back to zero and cancels the set programs. After a power failure, three zeros will flash on the panel.

Figure 21





SEMI - AUTOMATIC COOKING

This function is only used to set the END of the cooking time of the oven. There are two ways of setting this function.

1. Set the length of the cooking time by pushing the  button and the  button to advance, or  to go backwards (Fig. 21). This sets the desired "stop" time.



or

2. Set the end of the cooking time by pushing the  button and the  button to advance, or  to go backwards if you have passed the desired time (Fig. 22).

AUTO and the  symbol will be on.

Then set the temperature and the cooking program using the oven switch and thermostat knob (see relevant sections for details).

The oven is now set to turn on and off at the programmed times.

During cooking, the  symbol remains on and by pressing the button  you can see the time that remains till the end of the cooking.

The cooking time can be cancelled at any time by pushing the  button.

At the end of the cooking, the  symbol will turn off, the **AUTO** will flash and a buzzer will sound. The buzzer can be cancelled by pressing any of the buttons.

Turn the temperature and thermostat knobs to zero and set the programmer to "manual" by pressing the  button.

Figure 22



USE and CARE

PLURIFUNCTION OVEN

CAUTION:

- This appliance must be used only for the task it has explicitly been designed for, that is for domestic cooking of foodstuffs. Any other form of usage is to be considered as inappropriate and therefore dangerous.
- Do NOT place combustible materials or products on this appliance at any time.

USING THE OVEN FOR THE FIRST TIME

- Slide in the wire racks on the oven wall as in Fig. 23.
- Slide in the grease filter on the back of the oven as in Fig. 26.
- Position the shelf and tray as per Fig. 25.

Figure 23

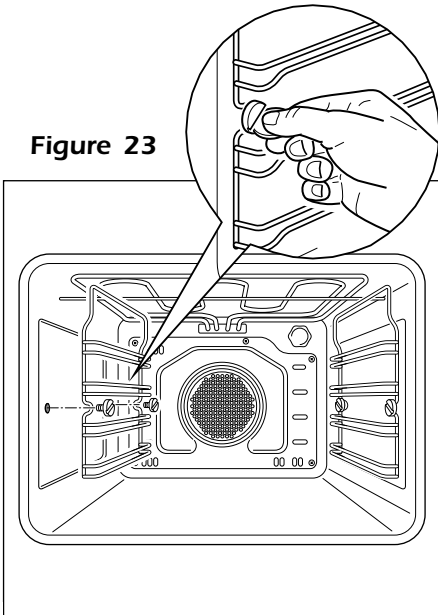
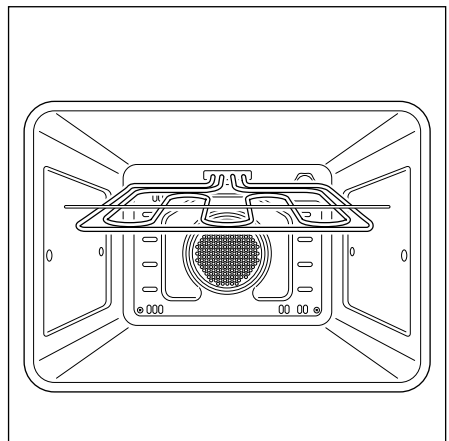



Figure 24



- To eliminate traces of grease and smell from the components it is necessary to pre-heat the oven at the maximum temperature.
 - For 60 minutes in the  position and for another 15 minutes in the  position.
- Slide off the wire racks to the oven wall as in Fig. 23. The grill is secured to the rear wall of the oven on a hinge system that allows it to be lowered to allow proper access when cleaning the oven ceiling (fig. 24).
- Clean the inside of the oven with a cloth soaked in water and neutral detergent and dry thoroughly.

GREASE FILTER

- A special screen is provided at the back of the oven to catch grease particles, mainly when meat is being roasted (fig. 26).
- When baking pastry etc. this filter should be removed.
- Always clean the filter after cooking as any solid residues on it might adversely affect the oven performance.

Figure 25

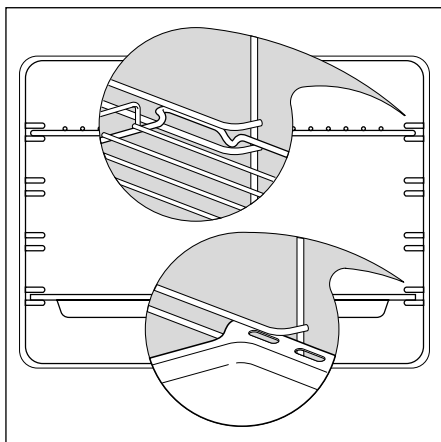
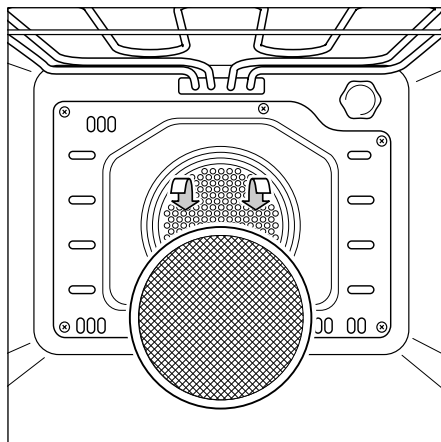
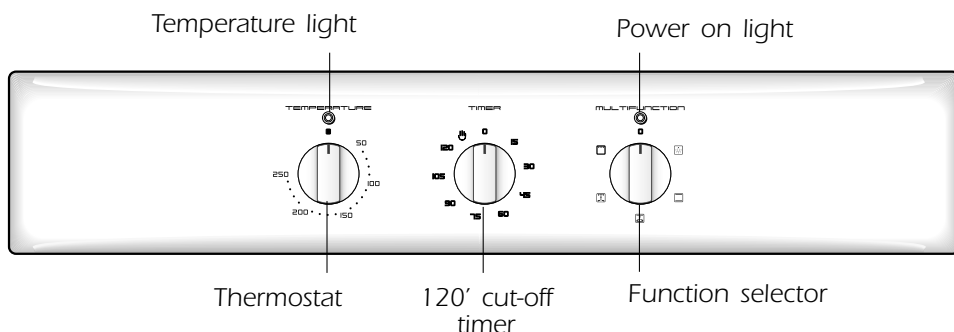

Figure 26



Cooking with plurifunction oven

Figure 27



GENERAL FEATURES

With your new Plurifunction oven it is possible to cook a variety of food using the 4 different cooking functions.

The 4 positions, thermostatically controlled, are obtained by 3 heating elements.

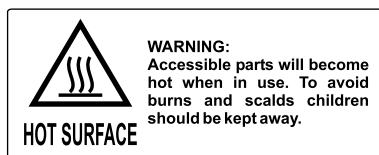

OPERATING PRINCIPLES

Heating and cooking in the 4 function PLURIFUNCTION oven are obtained in the following ways:

a. by normal convection

The heat is produced by the upper and lower heating elements.

b. by semi-forced convection

The heat produced by the upper and lower heating elements is distributed throughout the oven by the fan.

c. by radiation

The heat is radiated by the infra red grill element.

d. by radiation and ventilation

The radiated heat from the infra red grill element is distributed throughout the oven by the fan.

Figure 28

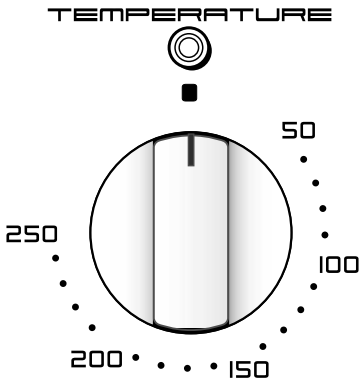

TEMPERATURE KNOB

This only sets the cooking temperature and does not switch the oven on. Rotate clockwise until the required temperature is reached (from 50 to 250°C).

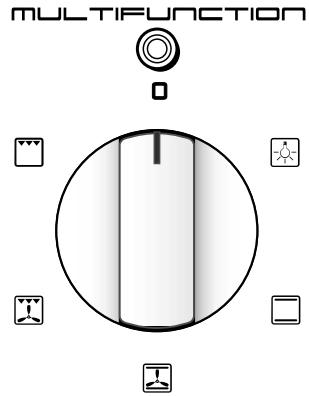

MULTIFUNCTION KNOB

Rotate the knob clockwise to set the oven for one of the following functions.



OVEN LIGHT

By setting the knob to this position, only the oven light comes on. It remains on in all the cooking modes.



TRADITIONAL BAKE

The upper and lower heating elements come on. The heat being dispersed by natural convection. The temperature range must be set between 50°C and 250°C using thermostat.

The oven must be preheated before cooking.

Ideal for:

Food that requires the same degree of cooking both inside and out, for example roasts, spare pork ribs, meringues etc.



MULTI-FUNCTION

The upper and lower heating elements come on and the fan comes on - the heat from the element being circulated by the fan.

The temperature range can be set to between 50° and 250°C using the thermostat.

Ideal for:

Large bulky quantities of food that require even cooking throughout for example large roasts, turkey, roast turkey, cakes etc.



FAN GRILL

Both the grill and the fan come on. Most of the cooking is done by grilling and then the hot air circulates around the oven. The oven door should be kept **closed**.

The temperature can be set between 50°C and 200°C max.

The oven should be preheated for 5 minutes before cooking. For further cooking hints see "GRILLING AND COOKING AU GRATIN".

Ideal for:

Quick sealing in of food juices for example such as hamburger, chicken pieces, chops.



GRILLING

The infrared grill element at the top of the oven comes on. The heat is dispersed by radiation.

Use with the **oven door closed** and the thermostat knob to position between 50°C and 200°C max.

For cooking hints, see the chapter "USE OF THE GRILL".

Ideal for:

Intense grilling, browning, cooking au gratin and toasting etc.

COOKING ADVICE

Remember to keep children away from the appliance when you use the grill or oven, since these parts become very hot.

STERILIZATION

Sterilization of foods to be preserved, in full and hermetically sealed jars, is done in the following way:

- Set the switch to position 
- Set the thermostat knob to position 175 °C and preheat the oven.
- Fill the dripping pan with hot water.
- Set the jars onto the dripping pan making sure they do not touch each other and the door and set the thermostat knob to position 130 °C.

When sterilization has begun, that is, when the contents of the jars start to bubble, turn off the oven and let cool.

Check your recycle book for full instructions.

WARMING BREAD

Set the switch to position  and the thermostat knob to position 150° C. Bread becomes fragrant again if wet with a few drops of water and put into the oven for about 10 minutes at the highest temperature.

SIMULTANEOUS COOKING OF DIFFERENT FOODS

The oven set on position  can cook several different foods together. Foods as diverse as fish and cakes can be cooked together without the cross transference of flavours. This is because the fats and cooking smell that would normally be deposited on the different foods are oxidised and are not absorbed by the foods. The cooking temperature of the foods, however must be within 20°-25°C of each other. The food with the longest cooking time will be put into the oven first and the other foods are added as necessary according to their cooking times.

ROASTING

To obtain classical roasting, it is necessary to remember:

- that it is advisable to maintain a temperature between 180° and 200 °C.
- that the cooking time depends on the quantity and the type of foods.

GRILLING AND “AU GRATIN”

As the hot air completely covers the food to be cooked, grilling may be done with the food on rack in the oven. The knob should be switched to position .

The thermostat should be set between 50° and 200°C max and the oven pre-heated.

The food should be placed on a rack in the oven for the required cooking time. Adding a few dabs of butter before the end of the cooking time gives the golden “au gratin” effect.

USE OF THE GRILL

Preheat the oven for about 5 minutes with the door closed.

Introduce the food to be cooked, positioning the rack as close to the grill as possible.

The dripping pan should be placed under the rack to catch the cooking juices and fats.

WARNING: Accessible parts may become hot when the grill is used. Children should be kept away.

How to use the timer

TIMER (Fig. 29)

The timer will operate the oven for a preset time.

1) Starting up

After setting the function selector and thermostat to the required mode and temperature, rotate the timer knob clockwise until you reach the required cooking time (max 120 minutes).

Once this time has elapsed, the timer will return to the "0" position and the oven will automatically switch off.

2) Manual position.

If the cooking time is longer than two hours or if you wish to use the oven manually, switching it off as required, the knob must be turned to position .

Figure 29



CLEANING and MAINTENANCE

GENERAL ADVICE

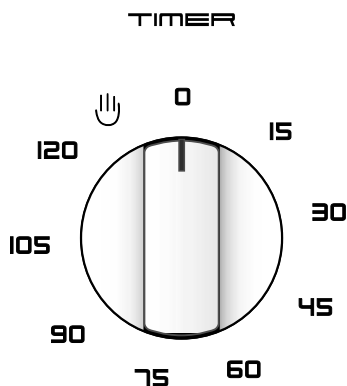
- **Before you begin cleaning, you must ensure that the appliance is switched off.**
- It is advisable to clean when the appliance is cold and especially when cleaning the enamelled parts.
- Avoid leaving alkaline or acidic substances (lemon juice, vinegar, etc.) on the surfaces.
- Avoid using cleaning products with a chlorine or acidic base.
- **Do not use a steam cleaner because the moisture can get into the appliance thus make it unsafe.**
- Stainless steel surfaces: clean with a suitable product. Always dry thoroughly.

INSIDE OF OVEN

The oven must be always cleaned after every use, using suitable products and keeping in mind that its operation for 30 minutes on the highest temperature eliminates most grime reducing it to ashes.

STAINLESS STEEL SURFACES (DMFPSII model)

CAUTION:

The stainless steel surfaces used in this oven are protected with a Special Lacquer to reduce finger-print marks.

To avoid damaging this lacquer, do not clean the stainless steel with abrasive cleaners or abrasive cloths or scouring pads.

ONLY SOAP/WARM WATER MUST BE USED TO CLEAN THE STAINLESS STEEL SURFACES.

GRILL HEATING ELEMENT

- The heating element is self-cleaning and does not require maintenance. The grill is secured to the rear wall of the oven on a hinge system that allows it to be lowered to allow proper access when cleaning the oven ceiling (fig. 12-24).

GREASE FILTER

- Clean the filter after any cooking! The grease filter can be removed for cleaning and should be washed regularly in hot soapy water (fig. 14-26).
- Always dry the filter properly before fitting it back into the oven.

Advice for use and maintenance of catalytic panels (models with catalytic panels)

The catalytic panels are covered with special microporous enamel which absorbs and does away with oil and fat splashes during normal baking over 200°C. If, after cooking very fatty foods, the panels remain dirty, operate the oven “idling” on max temperature for about 30 minutes. These panels do not require to be cleaned, however it is advised to periodically remove them from the oven (at least the side panels) and to wash them with tepid soapy water and then wipe off with a soft cloth.

DO NOT CLEAN OR WASH THEM WITH ABRASIVE PRODUCTS OR WITH PRODUCTS CONTAINING ACIDS OR ALKALIS.

The side panels are reversible and when the catalytic microporous enamel degrades, they can be turned to the other side.

REPLACING THE OVEN LAMP

WARNING: Ensure the appliance is switched off before replacing the lamp to avoid the possibility of electric shock.

- Let the oven cavity and the heating elements to cool down;
- Switch off the electrical supply;
- Unscrew the protective cover (fig. 30);
- Unscrew and replace the bulb with a new one suitable for high temperatures (300°C) having the following specifications:
230-240V 50 Hz, 15W (for DMFPSII model 25W), E14
- Refit the protective cover

NOTE: Oven bulb replacement is not covered by your guarantee

Figure 30

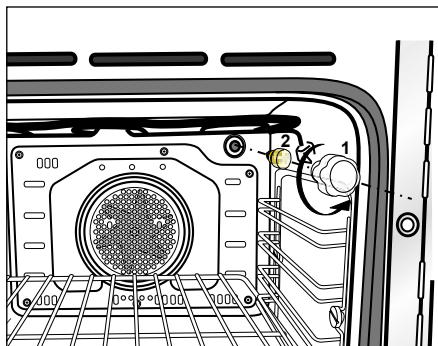

REMOVING THE OVEN DOOR

The oven door can easily be removed as follows:

- Open the door to the full extent (fig. 31a).
- Open the lever "A" completely on the left and right hinges (fig. 31b).
- Hold the door as shown in fig. 31.
- Gently close the door (fig. 31) until left and right hinge levers "A" are hooked to part "B" of the door (fig. 31b).
- Withdraw the hinge hooks from their location following arrow "C" (fig. 31d).
- Rest the door on a soft surface.
- To replace the door, repeat the above steps in reverse order.

Figure 31a

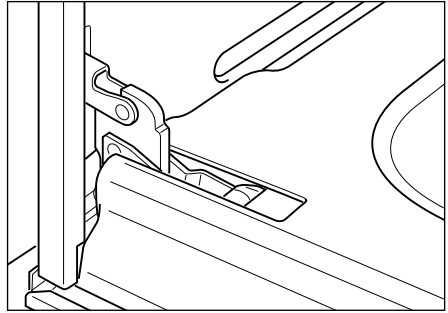

Figure 31b

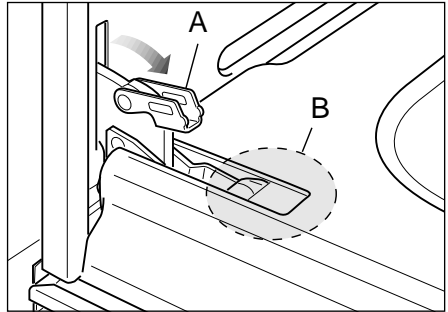

Figure 31c

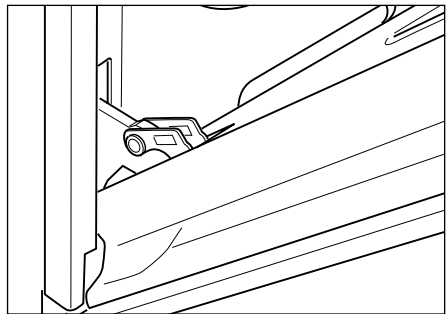

Figure 31d

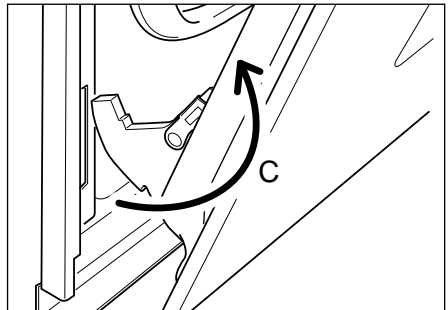

Figure 31

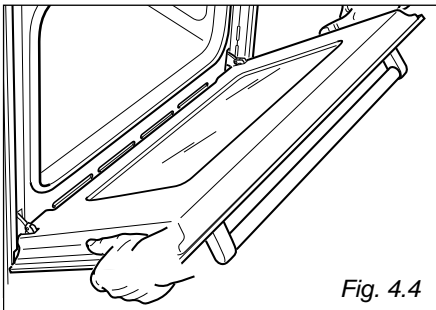

Fig. 4.4

TROUBLESHOOTING:

If you experience a problem with your oven, check the following points before calling our Customer Service Centre for assistance.

1. The power is switched on.
2. The controls are switched on.
3. The 120' cut-off or the electronic programmer are set to manual.
4. Both the fuse and the mains fuse are intact.

Should you still require assistance please contact our Customer Service Centre for your nearest Authorised Delonghi Service Agent.



Living innovation